

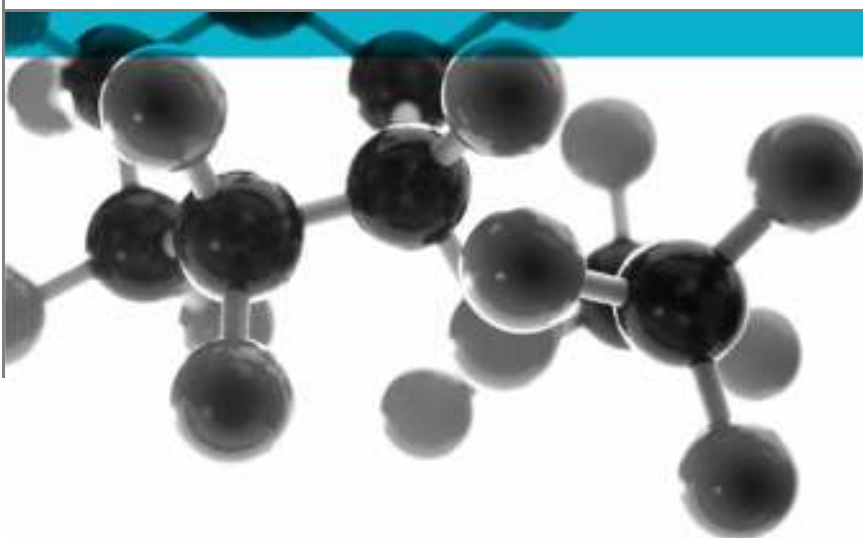

PAS 24:2016

Annex C



Test of: Ali Vu Multilight Casement

Enhanced security performance requirements for windows

A Report To:
Senior Architectural Systems
Eland Road, Denaby Main, Doncaster, DN12 4HA

Document Reference:
WIL 388463

Date: 28/02/2018

Copy: 1

Issue No.: 1

Page 1

Testing
Advising
Assuring



TEST CONCLUSIONS

Samples of:
 Manufacturer Senior Architectural Systems
 Product Multilight window
 Model Ali Vu Multilight Casement

have been tested in accordance with: PAS24:2016 Annex C.
 By Exova Wednesbury, a UKAS accredited Testing Laboratory (No. 0621)

At Unit 3 Wednesbury One, Black Country New Road, Wednesbury, WS10 7NZ.
 Results and comments as detailed below:

Clause No.	Description	Compliance
4	Enhanced security performance requirements	N/T
4.1.1	Classification of use	N/T
4.2	Infill medium	N/T
4.3	Letterplates	N/A
4.4	Classification	W
5	Marking	N/T
6	Design and general requirements	N/T
Annex C	Enhanced security performance for windows	YES
C.4.3	Manipulation test	YES
C.4.4.2	Infill manual test	YES
C.4.4.3	Infill mechanical test	YES
C.4.5	Mechanical loading test	YES
C.4.6	Manual check test	YES
C.4.7	Additional mechanical loading test	N/A

No inferences can be made regarding performance against other requirements of this standard

Tests marked N/A are not applicable to the sample under test.
 Tests marked N/T were not applied to the sample under test

AUTHORISATION

Tests performed by: Nick Steventon, Trainee Test Engineer
Sam Laxton, Trainee Test Engineer

Report issued by: Mark West, Door & Window Laboratory Manager

Signed



Date 27th February 2018

For and on behalf of Exova (UK) Ltd

Report authorised by: Chris Bryan, Senior Test Engineer

Signed



Date 27th February 2018

For and on behalf of Exova (UK) Ltd

Report issued: 28 February 2018



NOTE.

Tests marked "Not UKAS Accredited" are not covered by the Laboratory UKAS accreditation schedule.

The laboratory has tested the product supplied by the client as sampled in accordance with their own requirements

This report shall not be reproduced except in full, (and then only as permitted by copyright laws), without written approval from Exova (UK) Ltd.

Document No.: WIL 388463
Author: N Steventon
Client: Senior Architectural Systems

Page No.: 3 of 26
Issue Date: 28/02/2018
Issue No.: 1



CONTENTS	PAGE NO.
TEST CONCLUSIONS	2
AUTHORISATION.....	3
TEST DETAILS.....	5
TEST PROCEDURE	6
INITIAL OBSERVATIONS.....	7
TEST SPECIMEN	9
SCHEDULE OF COMPONENTS	13
PERFORMANCE CRITERIA & TEST RESULTS	19
CONCLUSIONS	25
LIMITATIONS	25
REVISION HISTORY	26

TEST DETAILS

CLIENT DETAILS

Company name Senior Architectural Systems
 Address Eland Road
 Denaby Main, Doncaster
 DN12 4HA

Contact Tom Grant

ORDER DETAILS

Order number 4100
 Dated 30/08/2017

SAMPLE DETAILS

Outer frame 3000 x 1600 x 68mm
 Opening casements TH: 1570 x 1570 x 68mm
 FIXED: 430 x 780mm
 SH: 950 x 1570mm

Configuration Top hung next to direct glazed over fixed light next to side hung
 Material Aluminium

Details of Hardware
 Hinges 2no. Senior Architectural side hung hinge SWFS16A
 2no. Senior Architectural top hung hinge SPW7HS24

Hinge protection 2no. pairs Senior Architectural hinge protector HCMA353309SC
 Lock Senior Architectural espag locking SPW7E7LH
 Handles Senior Architectural window handle INLINEB & SPIN9MM
 Seals Senior Architectural SP2400, SP2356 & SP7146
 Glazing details Double glazed

TEST DETAILS

Test specification PAS 24:2016
 Full test Yes
 Test to clauses Annex C

Sample received 11/10/2017
 Test started 12/10/2017
 Test completed 12/10/2017

Special Test requirements
 Other reports to be used in conjunction with this report

Document No.:	WIL 388463	Page No.:	5 of 26
Author:	N Steventon	Issue Date:	28/02/2018
Client:	Senior Architectural Systems	Issue No.:	1



TEST PROCEDURE

Introduction	<p>This test report should be read in conjunction with the Standard PAS 24:2016 Enhanced security performance requirements for doorsets and windows in the UK.</p> <p>The specimens were judged on their ability to comply with the performance criteria as required in PAS24:2016 Annex C.</p>
Instruction To Test	<p>Initial requirement was for a classification of W for windows.</p>
Test Specimen Construction	<p>A description of the test construction is given in the Schedule of Components. The description is based on a detailed survey of the specimens and information supplied by the sponsor of the test.</p>
Installation	<p>The window was supplied mounted within a aluminium sub-frame of nominal section 75 x 100mm fitted flush with the exterior face, in accordance with the clients fitting instructions.</p> <p>Mr Andrew Phillips, a representative of Senior Architectural witnessed the test.</p>
Sampling	<p>The samples were not independently witnessed or selected and were provided direct from the test sponsor.</p>
Test Climate	<p>The sample was conditioned in the laboratory in the range 15-30 °C and 25-75% humidity for at least 12 hours.</p> <p>The temperature and humidity in the lab was maintained in the range 19.5-21.4°C and 51.6-61.0% humidity for the duration of the test.</p>

Document No.:	WIL 388463	Page No.:	6 of 26
Author:	N Steventon	Issue Date:	28/02/2018
Client:	Senior Architectural Systems	Issue No.:	1



INITIAL OBSERVATIONS

The internal face of the sample



Sample hinge



Sample hinge protector



Sample handle



TEST SPECIMEN

Figure 1- General Elevation of Test Specimen (External Face)

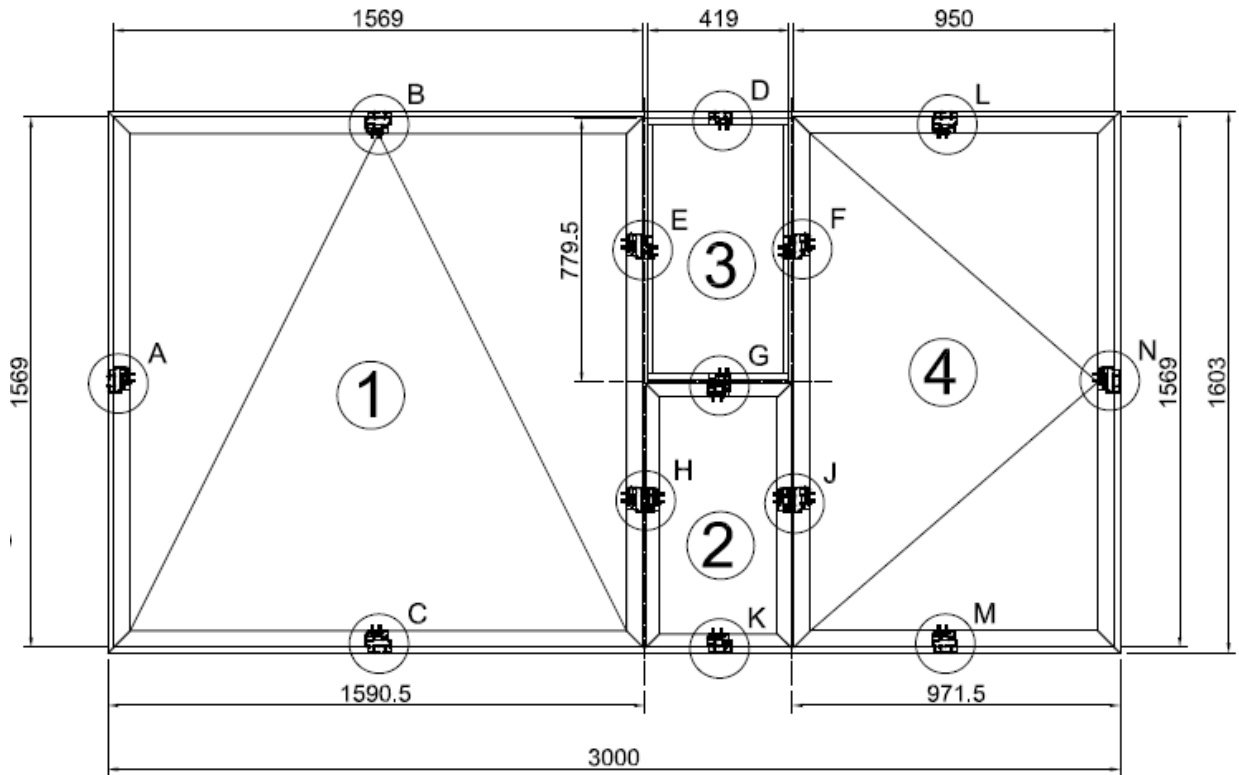

Do not scale. All dimensions are in mm

Figure 2 – Horizontal section through top hung, direct glazed and side hung

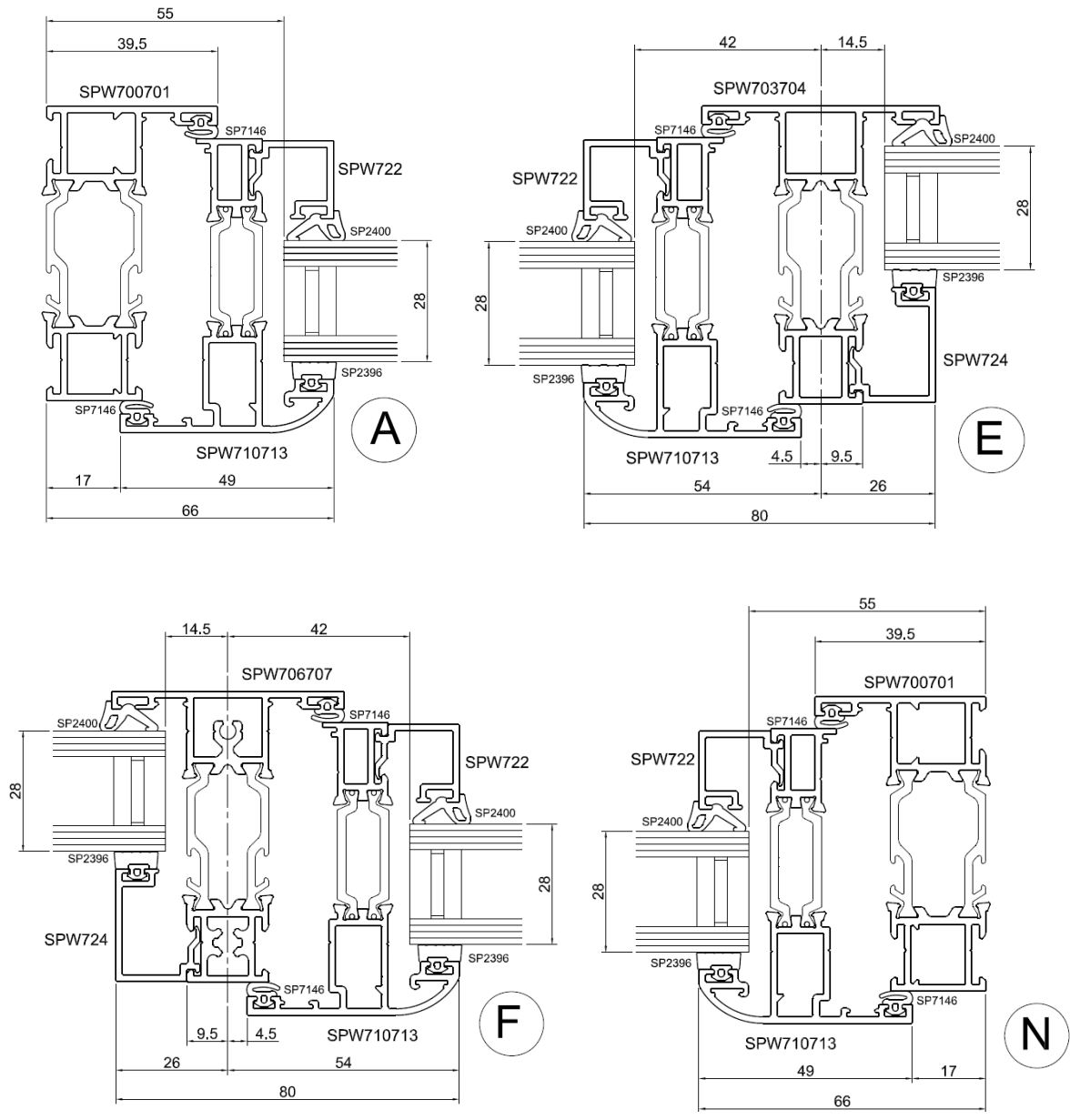

Do not scale. All dimensions are in mm

Figure 3 – Horizontal section through top hung, fixed and side hung

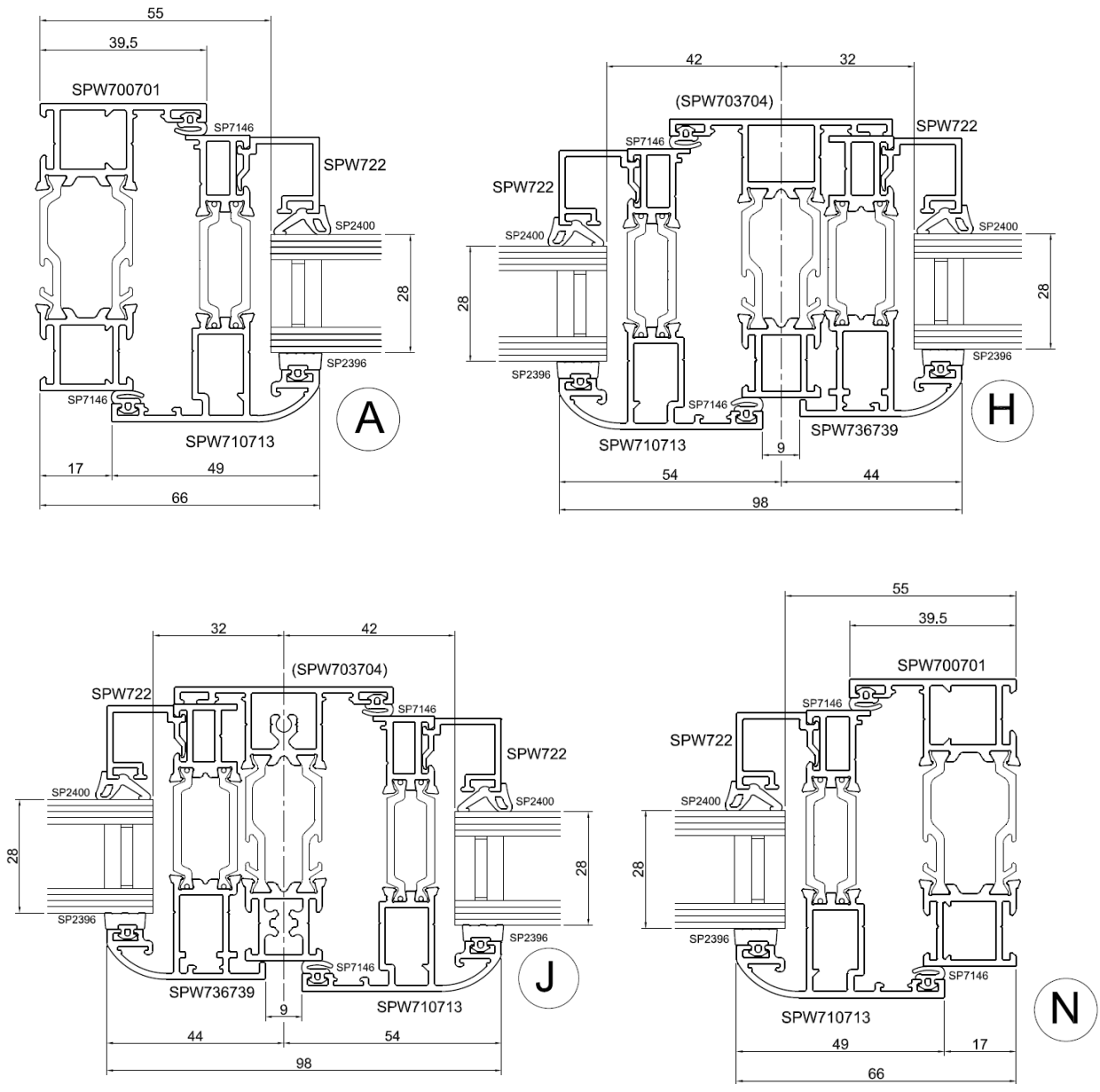

Do not scale. All dimensions are in mm

Figure 3 – Vertical section through top hung/side hung and fixed/direct

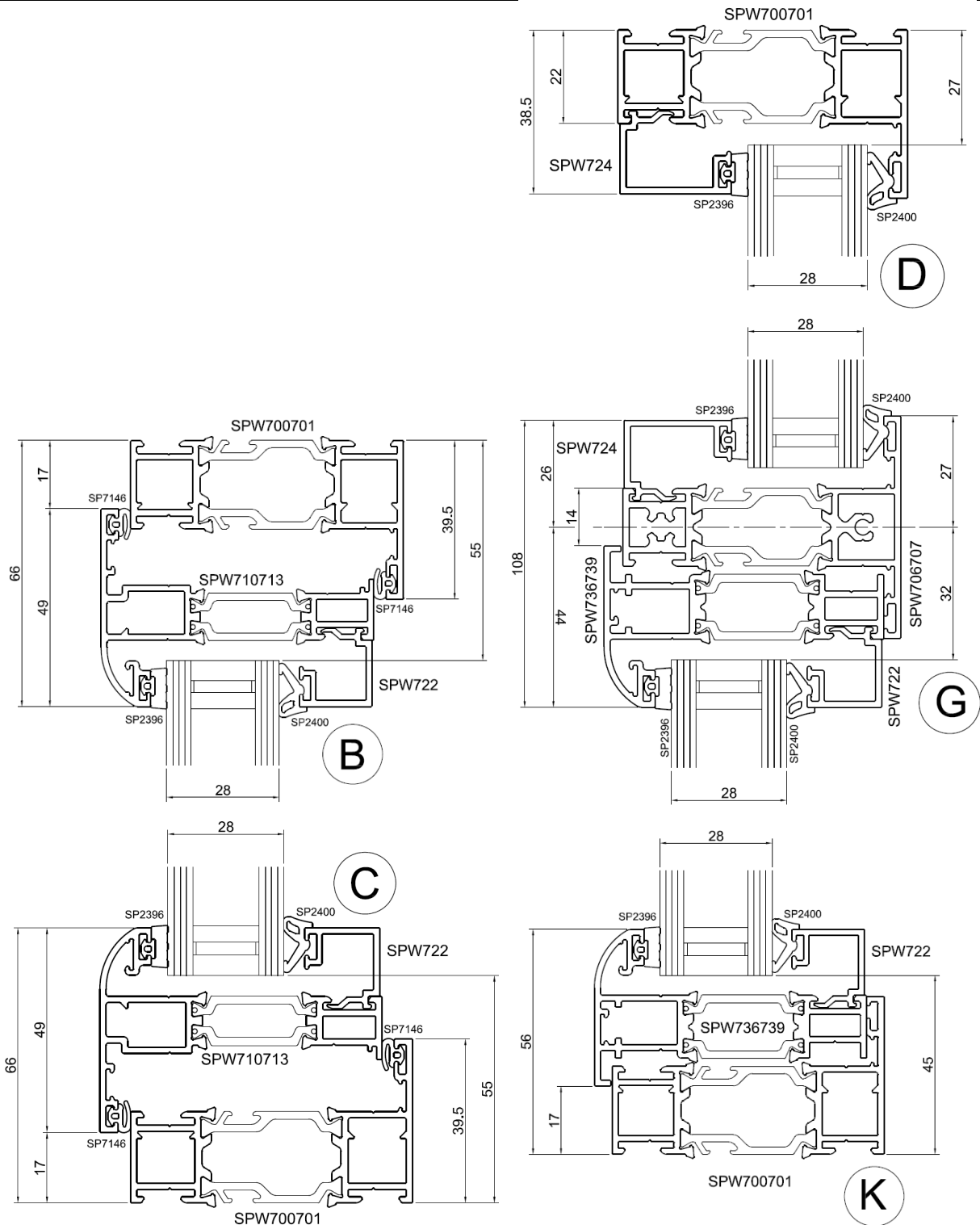

Do not scale. All dimensions are in mm

Document No.: WIL 388463

Author: N Steventon

Client: Senior Architectural Systems

Page No.: 12 of 26

Issue Date: 28/02/2018

Issue No.: 1



SCHEDULE OF COMPONENTS

(Refer to Figures 1 to 3)
 (All values are nominal unless stated otherwise)
 (All other details are as stated by the sponsor)

Variants

None

Item

Description

1. Window frame head, cill & Jamb

Supplier	:	SENIOR ARCHITECTURAL SYSTEMS LTD
Profile code	:	SPW700701
Material	:	Aluminium
Grade	:	6063 T6
Gauge / wall thickness	:	1.5mm
Thermal break material / method	:	Polyamide
Thermal break size	:	34mm
Glazing / casement rebate size	:	17.5mm
Section size	:	68 x 39.5mm
Fixing jamb to head joints		
i. type	:	Crimped Cleat SPW760CT14
ii. size	:	62mm x 62mm
iii. quantity	:	2 No. per Joint
Details of adhesive		
i. supplier	:	SENIOR ARCHITECTURAL SYSTEMS LTD
ii. reference	:	3COS0073 Cosmopur 819

2. Window frame mullion Shear block

Supplier	:	SENIOR ARCHITECTURAL SYSTEMS LTD
Profile code	:	SPW703704
Material	:	Aluminium
Grade	:	6063 T6
Gauge / wall thickness	:	1.5mm
Thermal break material / method	:	Polyamide
Thermal break size	:	34mm
Glazing / casement rebate size	:	17.5mm
Section size	:	68 x 54mm
Fixing mullion to head/sill/transom joints	:	
i. type	:	SPW762CT9 SPW763CT15
ii. size	:	28.2 x 9 x 13.15 25.5 x 15 x 13.5
iii. quantity	:	One No. Per Joint
iv. fixings	:	M4 x 6 Grub Screw No.8 x 16 Self Tapping Screw SFSG0406 SFSCS07
Details of adhesive		
i. supplier	:	SENIOR ARCHITECTURAL SYSTEMS LTD
ii. reference	:	3COS0073 Cosmopur 819

Item**Description****3. Window frame mullion Screw Port**

Supplier	:	SENIOR ARCHITECTURAL SYSTEMS LTD	
Profile code	:	SPW706707	
Material	:	Aluminium	
Grade	:	6063 T6	
Gauge / wall thickness	:	1.5mm	
Thermal break material / method	:	Polyamide	
Thermal break size	:	34mm	
Glazing / casement rebate size	:	17.5mm	
Section size	:	68 x 54mm	
Fixing mullion to head/sill/transom joints	:		
i. type	:	SFSCS1238	SFSCS29
ii. size	:	No.12x38 C'sk Screw	No.8x38 C'sk Screw
iii. quantity	:	One No. Per Joint	One No. Per Joint
Details of adhesive			
iii. supplier	:	SENIOR ARCHITECTURAL SYSTEMS LTD	
iv. reference	:	3COS0073 Cosmopur 819	

4. Rebate reverser on transom

Supplier	:	SENIOR ARCHITECTURAL SYSTEMS LTD	
Profile code	:	SPW736739	
Material	:	Aluminium	
Grade	:	6063 T6	
Gauge / wall thickness	:	1.5mm	
Thermal break material / method	:	Polyamide	
Thermal break size	:	30mm	
Glazing / casement rebate size	:	17.5mm	
Section size	:	68 x 39mm	
Fixing To Transom/Mullion	:		
i. type	:	SFSCS30	
ii. size	:	No.8x25mm C'sk Screw	
iii. quantity	:	100mm From Corners, Max 600mm Crs	
Details of adhesive			
i. supplier	:	SENIOR ARCHITECTURAL SYSTEMS LTD	
ii. reference	:	3COS0073 Cosmopur 819	

5. Bead into OuterFrame Fixed Light

Supplier	:	SENIOR ARCHITECTURAL SYSTEMS LTD	
Profile code	:	SPW724	
Material	:	Aluminium	
Grade	:	6063 T6	
Gauge / wall thickness	:	1.5mm	
Section size	:	19.5mm x 26mm	
Fit	:	Clip In	
	:		

<u>Item</u>	<u>Description</u>
6. Window frame weather seals outer	
Supplier	: SENIOR ARCHITECTURAL SYSTEMS LTD
Reference	: SP7146
Material	: EPDM
Fixing method	: Push Fit
7. Window frame weather seals Inner	
Supplier	: SENIOR ARCHITECTURAL SYSTEMS LTD
Reference	: SP7146
Material	: EPDM
Fixing method	: Push Fit
8. Window casement (s)	
Overall Size	
i. top hung casement Vent	: 1569 x 1569mm
ii. side hung casement Vent	: 950 x 1569mm
iii. fixed casement	: 492 x 828.5mm
iii. fixed casement rebate reversed	: 429 x 780mm
Profile codes	
i. vent profile code	: SPW710713
ii. rebate reverser profile code	: SPW736739
Material	: Aluminium
Grade	: 6063 T6
Gauge / wall thickness	: 1.5mm
Thermal break material / method	: Polyamide
Thermal break size	: 30mm
Glazing rebate size	: 16.5mm
Casement framing section size	
i. vent	: 68 x 49mm
ii. rebate reverser	: 68 x 39mm
Corner fixing method	:
i. type	: Crimped Cleat SPW760CT14 SPW761CT12
ii. size	: 62 x 62mm
iii. quantity	: One No. Each per Corner
Adhesive	:
i. supplier	: SENIOR ARCHITECTURAL SYSTEMS LTD
ii. reference	: 3COS0073 Cosmopur 819
9. Window casement glass	
Supplier	: SENIOR GLASS
Thickness / configuration	: 28mm 4/20/4
Overall size	
i. top hung casement	: 1493.5 x 1493.5mm
ii. side hung casement	: 874.5 x 1493.5mm
iii. fixed casement	: 409 x 760mm
iv. rebate reversed fixed light	: 373.5 x 724.5mm
Nominal edge clearance	: 11.5mm

<u>Item</u>	<u>Description</u>
10. Glazing setting blocks	Casement Vent & Reversed
Supplier	: SENIOR ARCHITECTURAL SYSTEMS LTD
Material	: PVC
Thickness	: SPW7GP2 4mm SGP28mmx1mm 1mm
Section size	: 53mm x 4mm x 100mm 28mm x 1mm x 100mm
11. Glazing setting blocks	Fixed Light
Supplier	: SENIOR ARCHITECTURAL SYSTEMS LTD
Material	: PVC
Thickness	: SGP28mmx5mm
Section size	: 28mm x 5mm x 100mm
12. Glazing gasket	
Supplier	: SENIOR ARCHITECTURAL SYSTEMS LTD
Reference	: External SP2396 Internal SP2400
Fixing method	: Captive Wedge
13. Glazing beads	
Glazing method	: Internally bead External Bead
Supplier	: SENIOR ARCHITECTURAL SYSTEMS LTD
Profile code	: SPW722 SPW724
Material	: Aluminium
Grade	: 6063 T6
Gauge / wall thickness	: 1.5mm
Section size	: 19.5mm x 18mm 19.5mm x 26mm
Fixing method	: Clip In
14. Weather Seal Gasket	
Supplier	: SENIOR ARCHITECTURAL SYSTEMS LTD
Description	: Flipper Gasket
Reference	: SP7146
Material	: EPDM
Fixings	: Push Fit
15. Hinges	
Supplier	: SENIOR ARCHITECTURAL SYSTEMS LTD
Description	: Top Hung Friction Stay Side Hung Friction Stay
Reference	: SPW7HS24 SWFS16A
Material	: Austenitic/Ferritic Steel Austenitic Steel
Quantity	: One No. Pair Per Vent
Fixing hinge to casement	
iii. type	: SFSF0810 SFSCS0716 SFSF0810
iv. size	: No.8x10mm No.7x16mm No.8x10
v. quantity	: 5No. Per Hinge One No. Per Hinge 2No per Hinge
Fixing hinge to frame	
i. type	: SFSBP0810 SFSF0810
ii. size	: No.8x10mm No.8x10
iii. quantity	: 4No. Per Hinge 3No. Per Hinge



<u>Item</u>	<u>Description</u>
16. Hinge protectors	
Supplier	: SENIOR ARCHITECTURAL SYSTEMS LTD
Description	: Hinge protector
Reference	: HCMA353309SC
Material	: Metal
Quantity	: 4No. Per Window
Position	: 105mm in from the vent edge
Fixing device to casement	
i. type	: SFSBC0809
ii. size	: No.8x9.5mm
iii. quantity	: 2No. Per Hinge protector
Fixing device to frame	
i. type	: SFSCS07
ii. size	: No.8x16mm
iii. quantity	: 2No. Per Hinge protector
17. Lock	
Supplier	: SENIOR ARCHITECTURAL SYSTEMS LTD
Description	: Espag Rod
Reference	: SPW7E7LH
Material	: Stainless Steel
Fixings	
i. type	: SFSBC0809
ii. size	: No.8x9.5mm
iii. quantity	: 10No.
18. Lock Keeps	
Supplier	: SENIOR ARCHITECTURAL SYSTEMS LTD
Description	: Cam Keep
Reference	: SPW7CK
Material	: Zinc ZL5
Quantity	: 4No.
Fixing keeps to frame	
i. type	: SFSCS07 SFSCS0819
ii. size	: No.8x16mm No.8x19mm
iii. quantity	: 2No. Per Keep One No. Per Keep
19. Lever handles	
Supplier	: SENIOR ARCHITECTURAL SYSTEMS LTD
Description	: Espag Handle Plus Spindle
Reference	: INLINEB & SPIN9MM
Material	: Metal
Fixings	
i. type	: SFSCM0516
ii. size	: M5x16mm
iii. quantity	: 2No. Per Handle

Item**Description****20. Side Hung Hinge Guide**

Supplier	:	SENIOR ARCHITECTURAL SYSTEMS LTD
Description	:	Side Hung Hinge Guide
Reference	:	SPW7HG
Material	:	PVC
Quantity	:	One No. Per Vent
Position	:	Bottom Of Vent, Hinge Side
Fixing restrictor to casement		
i. type	:	SFSBC0809
ii. size	:	No.8x9.5mm
iii. quantity	:	2No. Per Guide

21. Locking Wedges

Supplier	:	SENIOR ARCHITECTURAL SYSTEMS LTD
Description	:	Locking Wedges
Reference	:	SP300121B SPW7LWP
Material	:	PVC
Quantity	:	4No. Per Vent 2No. Per vent
Position	:	One third Of vent Width/Height from Each Edge
Fixing restrictor to casement		
i. type	:	SFSCS07
ii. size	:	No.8 x 16mm
iii. quantity	:	2No. Per Wedge
Fixing restrictor to frame		
i. type	:	SFSCS07
ii. size	:	No.8 x 16mm
iii. quantity	:	2No. Per Wedge

22. Run-Up Blocks

Supplier	:	SENIOR ARCHITECTURAL SYSTEMS LTD
Description	:	Run-Up Blocks
Reference	:	SPW7RB
Material	:	PVC
Quantity	:	2No. Per vent
Position	:	290mm Either Side Of Centre Of Frame
Fixing restrictor to frame		
i. type	:	SFSCS07
ii. size	:	No.8 x 16mm
iii. quantity	:	One No. Per Wedge

PERFORMANCE CRITERIA & TEST RESULTS

Clause	Result		Compliance
4.1.1 Classification of use	Windows shall be classified according to their intended use for all relevant characteristics in accordance with BS 6375 and the relevant material specific standard.	Performance not assessed	N/T
4.1.3 Windows	Windows must meet the requirements of Annex C of PAS24:2016 or RC2N of BS EN 1627	Window meets the requirements of Annex C of PAS24.	YES
4.2 Infill medium requirements	Where non-key locking hardware is fitted each glazed area shall include at least one pane of laminated glass meeting the requirements of BS EN 356:2000 Class P1A.	Performance not assessed	N/T
4.3 Letterplates	No letterplate fitted		N/A
4.4 Classification	Following testing to Annex C the final classification shall be determined as W for a window.	Window classified as W.	W
5 Marking	<p>Window assembly shall be permanently marked, in a position that is visible and accessible when the window is open, with the following information:</p> <ul style="list-style-type: none"> The number and date of the specification and the classification, i.e. PAS24:2016 W. The date of manufacture (at least year and quarter) The name or trade mark or other means of identifying the manufacturer 	Performance not assessed	N/T

Clause	Result	Compliance
6.2 Installation instructions	The manufacturer shall supply full instructions for assembly, installation and maintenance	Performance not assessed N/T

Clause	Result	Pass / Fail
Annex C: Enhanced security performance requirements for windows		
C.4.3 Manipulation test	<p>Attacks were made with a screwdriver to the locking point on the top hung casement to try and manipulate the locking point. Total attack time was 3 minutes but entry was not achieve.</p> <p>Attacks were made with a paint scraper to the locking point on the top hung casement to try and manipulate the locking point. Total attack time was 3 minutes but entry was not achieved.</p> <p>Attacks were made with a screwdriver to the locking point on the side hung casement to try and manipulate the locking point. Total attack time was 3 minutes but entry was not achieved.</p> <p>Attacks were made with a paint scraper to the locking point on the side hung casement to try and manipulate the locking point. Total attack time was 3 minutes but entry was not achieved.</p> <p>Attacks were made with a craft knife to the hinge point on the side hung casement to try and cut out the the hinge point. Total attack time was 3 minutes but entry was not achieved.</p>	PASS
C.4.4.2 Manual test on infill	<p>Fixed casement glazing Attacks were made with a 6mm chisel and craft knife to try and cut out the gasket and push the glazing out. Total attack time was 3 minutes but entry could not be achieved.</p> <p>Direct glazing Attacks were made with a 25mm chisel to try and remove the bottom beading. Total attack time was 3 minutes but entry could not be achieved.</p>	PASS
C.4.4.3 Mechanical test on infill	<p>Top hung casement glazing 2000N load applied to all four corners for 10s entry not achieved.</p> <p>Direct glazing 2000N load applied to all four corners for 10s entry not achieved.</p> <p>All loads were held and no entry was achieved</p>	PASS
C.4.5 Mechanical loading test – Top hung casement	<p>Attempts to apply Mechanical loads to all the hinge points and locking points were made with the following results obtained.</p> <p>Point 1: Top hinge/vector excluder 1kN parallel load (down) and 3kN perpendicular load held for 10s. 1kN parallel load (horizontal) and 3kN perpendicular load held for 10s.</p> <p>Point 2: Free corner 1kN parallel load (across) and 3kN perpendicular load held for 10s. 1kN parallel load (up) and 3kN perpendicular load held for 10s.</p>	PASS

Clause	Result	Pass / Fail
	<p>Point 3: 1st locking point 1kN parallel load (across) and 3kN perpendicular load held for 10s. 1kN parallel load (across) and 3kN perpendicular load held for 10s. 1kN parallel load (up) and 3kN perpendicular load held for 10s.</p> <p>Point 4: 2nd locking point 1kN parallel load (across) and 3kN perpendicular load held for 10s. 1kN parallel load (across) and 3kN perpendicular load held for 10s. 1kN parallel load (up) and 3kN perpendicular load held for 10s.</p> <p>Point 5: 1st locking point 1kN parallel load (across) and 3kN perpendicular load held for 10s. 1kN parallel load (across) and 3kN perpendicular load held for 10s. 1kN parallel load (up) and 3kN perpendicular load held for 10s.</p> <p>Point 6: 1st locking point 1kN parallel load (across) and 3kN perpendicular load held for 10s. 1kN parallel load (across) and 3kN perpendicular load held for 10s. 1kN parallel load (up) and 3kN perpendicular load held for 10s.</p> <p>Point 7: Free corner 1kN parallel load (across) and 3kN perpendicular load held for 10s. 1kN parallel load (up) and 3kN perpendicular load held for 10s.</p> <p>Point 8: Top hinge/vector excluder 1kN parallel load (down) and 3kN perpendicular load held for 10s.</p> <p>All loads were held and no entry was achieved.</p>	
C.4.5 Mechanical loading test – Side hung casement	<p>Attempts to apply Mechanical loads to all the hinge points and locking points were made with the following results obtained.</p> <p>Point 1: Top hinge/vector excluder 1kN parallel load (down) and 3kN perpendicular load held for 10s. 1kN parallel load (horizontal) and 3kN perpendicular load held for 10s.</p> <p>Point 2: Free corner 1kN parallel load (across) and 3kN perpendicular load held for 10s. 1kN parallel load (up) and 3kN perpendicular load held for 10s.</p> <p>Point 3: 1st locking point 1kN parallel load (across) and 3kN perpendicular load held for 10s. 1kN parallel load (across) and 3kN perpendicular load held for 10s. 1kN parallel load (up) and 3kN perpendicular load held for 10s.</p> <p>Point 4: 2nd locking point 1kN parallel load (across) and 3kN perpendicular load held for 10s. 1kN parallel load (across) and 3kN perpendicular load held for 10s. 1kN parallel load (up) and 3kN perpendicular load held for 10s.</p> <p>Point 5: 1st locking point 1kN parallel load (across) and 3kN perpendicular load held for 10s.</p>	PASS

Document No.: WIL 388463

Page No.: 22 of 26

Author: N Steventon

Issue Date: 28/02/2018

Client: Senior Architectural
Systems

Issue No.: 1



Clause	Result	Pass / Fail
	<p>1kN parallel load (across) and 3kN perpendicular load held for 10s. 1kN parallel load (up) and 3kN perpendicular load held for 10s.</p> <p>Point 6: 1st locking point 1kN parallel load (across) and 3kN perpendicular load held for 10s. 1kN parallel load (across) and 3kN perpendicular load held for 10s. 1kN parallel load (up) and 3kN perpendicular load held for 10s.</p> <p>Point 7: Free corner 1kN parallel load (across) and 3kN perpendicular load held for 10s. 1kN parallel load (up) and 3kN perpendicular load held for 10s.</p> <p>Point 8: Top hinge/vector excluder 1kN parallel load (down) and 3kN perpendicular load held for 10s. 1kN parallel load (horizontal) and 3kN perpendicular load held for 10s.</p> <p>All loads were held and no entry was achieved.</p>	
C.4.5 Mechanical loading test – Fixed casement	<p>Attempts to apply Mechanical loads to all the hinge points and locking points were made with the following results obtained.</p> <p>Point 1: 1st fixing 1kN parallel load and 3kN perpendicular load held for 10s.</p> <p>Point 2: 2nd fixing 1kN parallel load and 3kN perpendicular load held for 10s.</p> <p>Point 2: 2nd fixing 1kN parallel load and 3kN perpendicular load held for 10s.</p> <p>Point 2: 2nd fixing 1kN parallel load and 3kN perpendicular load held for 10s.</p> <p>Point 2: 2nd fixing 1kN parallel load and 3kN perpendicular load held for 10s.</p> <p>Point 2: 2nd fixing 1kN parallel load and 3kN perpendicular load held for 10s.</p> <p>All loads were held and no entry was achieved.</p>	PASS

Clause	Result	Pass / Fail
--------	--------	-------------

Defined mechanical loading points



C.4.6 Manual check test

Attacks were made with a screwdriver and nail bar to try and lever the window open between a hinge and locking point on the top hung casement. Total attack time was 3 minutes but entry was not achieved.

**PASS
NO
VULNER-
ABILITY
IDENTIFIED**

Attacks were made with a screwdriver and nail bar to try and lever the window open between locking points on the top hung casement. Total attack time was 3 minutes but entry was not achieved.

Attacks were made with a screwdriver and nail bar to try and lever the window open between a hinge and locking point on the side hung casement. Total attack time was 3 minutes but entry was not achieved.

Attacks were made with a screwdriver and nail bar to try and lever the window open between a hinge points on the side hung casement. Total attack time was 3 minutes but entry was not achieved.

Attacks were made with a screwdriver and nail bar to try and lever the window open between a locking points on the side hung casement. Total attack time was 3 minutes but entry was not achieved.

C.4.7 Additional mechanical loading test

Testing was not required as no vulnerabilities were identified in the manual check test.

**NOT
REQUIRED**

CONCLUSIONS

Evaluation against objective The windows as provided by the client were subjected to enhanced security testing in accordance with PAS24:2016 Annex C and achieved the requirements for a classification of W for windows.

Observations & comments

LIMITATIONS

Limitations The results relate only to the behaviour of the specimens of the element of construction under the particular conditions of test. They are not intended to be the sole criteria for assessing the potential performance of the element in use, nor do they reflect the actual behaviour in use.

Range of assemblies covered by this report It is our opinion that the range of assemblies covered by this report are limited to the following

- Assemblies with identical hardware fitted no further apart than in the tested assembly
- Assemblies of the same or smaller overall dimensions to the tested assembly

Uncertainty of Measurement The uncertainties of measurements calculated for a confidence level of 95% throughout these tests are within the limits of these tolerances.

Document No.:	WIL 388463	Page No.:	25 of 26
Author:	N Steventon	Issue Date:	28/02/2018
Client:	Senior Architectural Systems	Issue No.:	1



REVISION HISTORY

This issue of the report replaces all previous issues that are now withdrawn.

Issue No :	Re - Issue Date :
Revised By:	Approved By:
Reason for Revision:	
Issue No :	Re - Issue Date :
Revised By:	Approved By:
Reason for Revision:	

END OF REPORT